

Profil oblique à 30°

Fonte grise

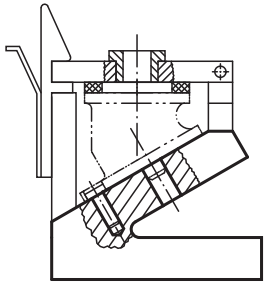

Matière :
Fonte grise EN GJL 250 stabilisée.
Exemple de commande :
nIm 01840-02X600
(Indiquer la longueur «L»)

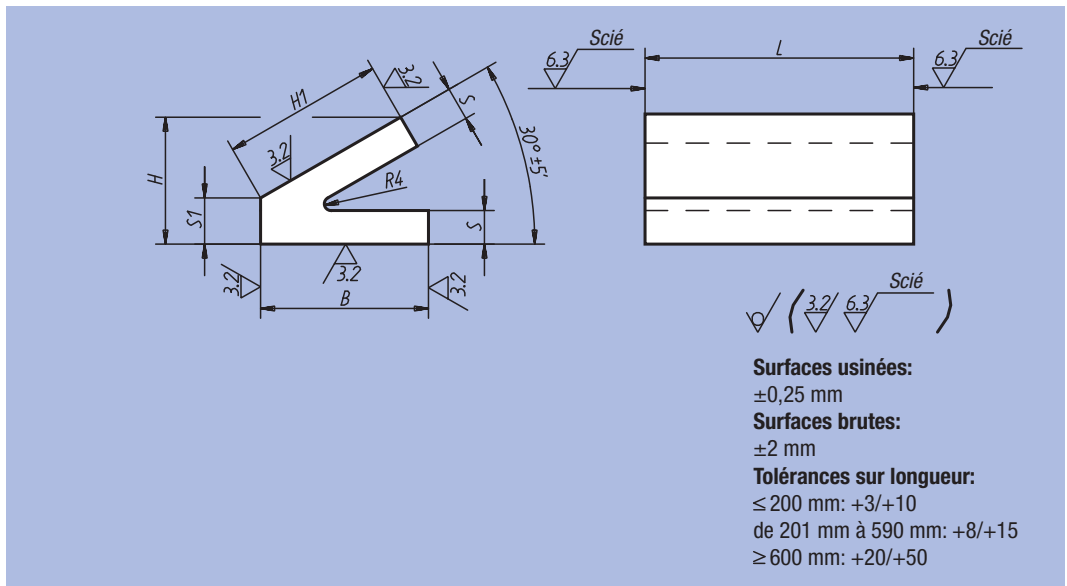

Référence	L = Longueur	B	H	H1	S	S1	⊞ kg, L/100
01840-02X	300 / 600	100	77,5	100	20	27,5	2,9
01840-05X	600 / 600	200	144	200	32	44	9,2

Notes :

Grid area for notes.