

## Profil creux carré

Fonte grise



**Matière :**

Fonte grise EN GJL 250 stabilisée.

**Exemple de commande :**

nlm 01740-06X200

(Indiquer la longueur «L»)

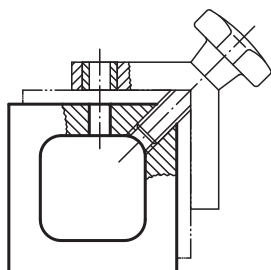
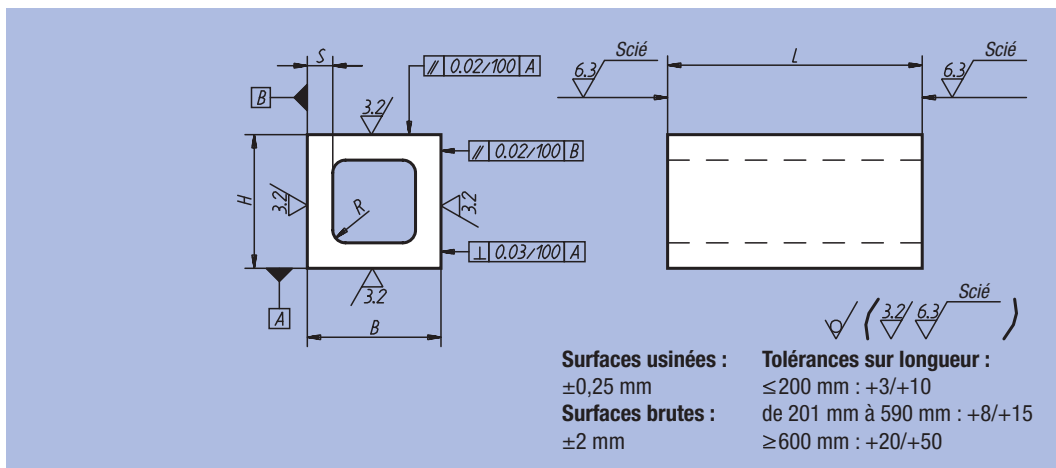

Référence	L = Longueur	B	H	≈ S	R	⊠ kg, L/100
01740-04X	100 / 200	63	63	12	6	1,80
01740-05X	200 / 400	80	80	18	8	3,75
01740-06X	200 / 400	100	100	20	10	4,70
01740-07X	200 / 400 / 600	125	125	22	12	6,65
01740-08X	200 / 300 / 600	160	160	25	16	10,00
01740-09X	200 / 300 / 600	200	200	28	20	14,45
01740-12X	600	250	250	36	20	22,80
01740-15X	600	315	315	56	20	42,50

## Profil creux rectangulaire

Fonte grise



**Matière :**

Fonte grise EN GJL 250 stabilisée.

**Exemple de commande :**

nlm 01760-04X300

(Indiquer la longueur «L»)

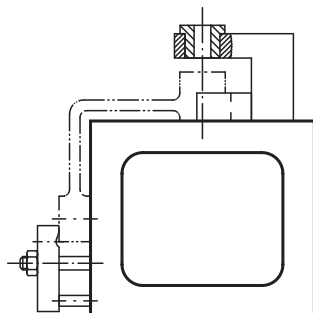
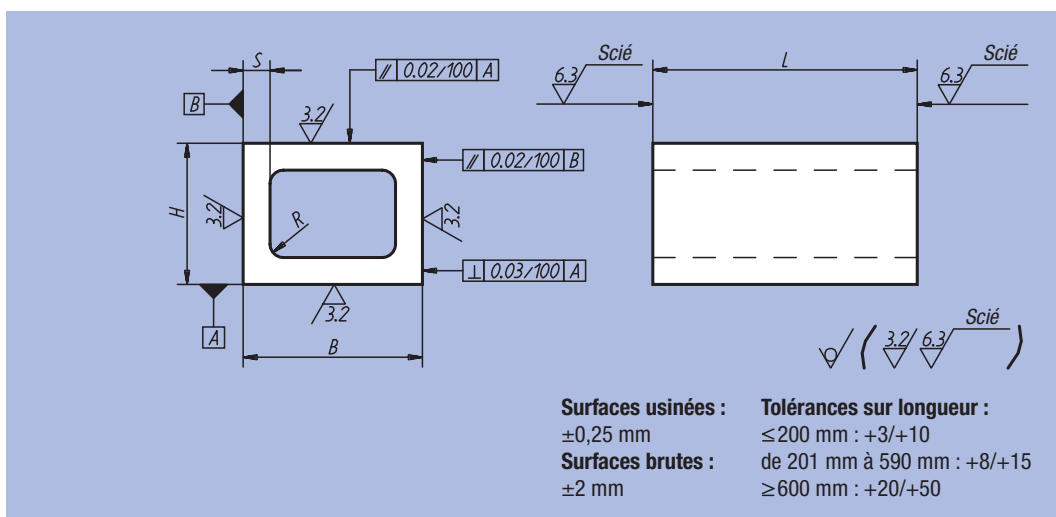

Référence	L = Longueur	B	H	≈ S	R	⊠ kg, L/100
01760-01X	100 / 200	80	63	12	6	2,10
01760-02X	200 / 400	100	80	16	8	3,50
01760-03X	200 / 300 / 600	160	100	22	10	7,25
01760-04X	200 / 300 / 600	200	160	25	16	11,35
01760-05X	300 / 600	250	200	28	20	16,17