

Profil en U

Fonte grise et aluminium



Matière :
Fonte grise EN GJL 250 stabilisée ou Aluminium EN AW-7075.

Exemple de commande :
nIm 01680-06X300
(Indiquer la longueur «L»)

Sur demande :
Longueurs 800 mm et 1000 mm en fonte grise.

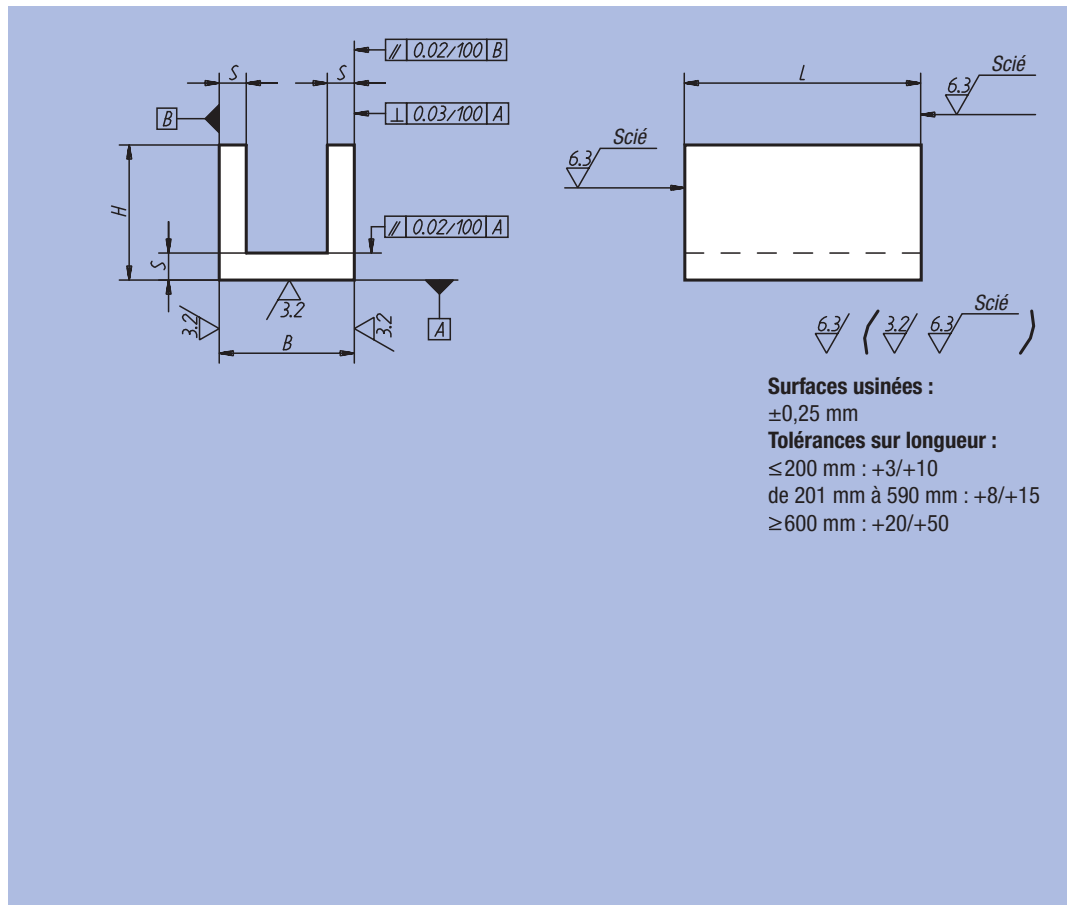
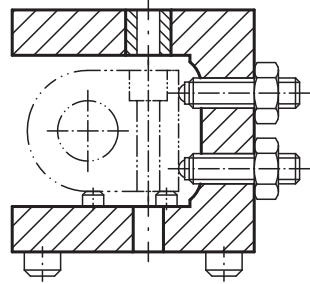

Surfaces usinées :
±0,25 mm
Tolérances sur longueur :
≤200 mm : +3/+10
de 201 mm à 590 mm : +8/+15
≥600 mm : +20/+50

Référence	Finition	L = Longueur	B	H	S	⊞ kg, L/100
01680-01X	Fonte grise	150 / 300	32	32	8	0,47
01680-02X	Fonte grise	150 / 300	40	40	10	0,73
01680-03X	Fonte grise	150 / 300 / 600	63	63	12	1,47
01680-04X	Fonte grise	200 / 300 / 600 / 800	80	80	16	2,50
01680-05X	Fonte grise	200 / 300 / 600 / 1000	100	100	20	3,75
01680-06X	Fonte grise	200 / 300 / 600 / 1000	125	125	20	4,85
01680-07X	Fonte grise	200 / 300 / 600	160	160	25	7,75
01680-08X	Fonte grise	200 / 300 / 600	200	200	32	12,50
01680-09X	Fonte grise	300 / 600	250	250	36	17,60
01680-10X	Fonte grise	300 / 600	250	200	36	15,00
01680-11X	Fonte grise	300 / 600	315	200	36	16,67
01680-201X	Aluminium	150 / 300	32	32	8	0,16
01680-202X	Aluminium	150 / 300	40	40	10	0,25
01680-203X	Aluminium	150 / 300 / 600	63	63	12	0,50
01680-204X	Aluminium	200 / 300 / 600 / 800	80	80	16	0,85
01680-205X	Aluminium	200 / 300 / 600 / 1000	100	100	20	1,30
01680-206X	Aluminium	200 / 300 / 600 / 1000	125	125	20	1,67
01680-207X	Aluminium	200 / 300 / 600	160	160	25	2,67
01680-208X	Aluminium	200 / 300 / 600	200	200	32	4,30
01680-209X	Aluminium	300 / 600	250	250	36	6,05
01680-210X	Aluminium	300 / 600	250	200	36	5,15
01680-211X	Aluminium	300 / 600	315	200	36	5,73