

Profil en L

Fonte grise et aluminium



Matière :
Fonte grise EN GJL 250 stabilisée ou
Aluminium EN AW-7075.

Exemple de commande :
nIm 01380-04X300
(Indiquer la longueur «L»)

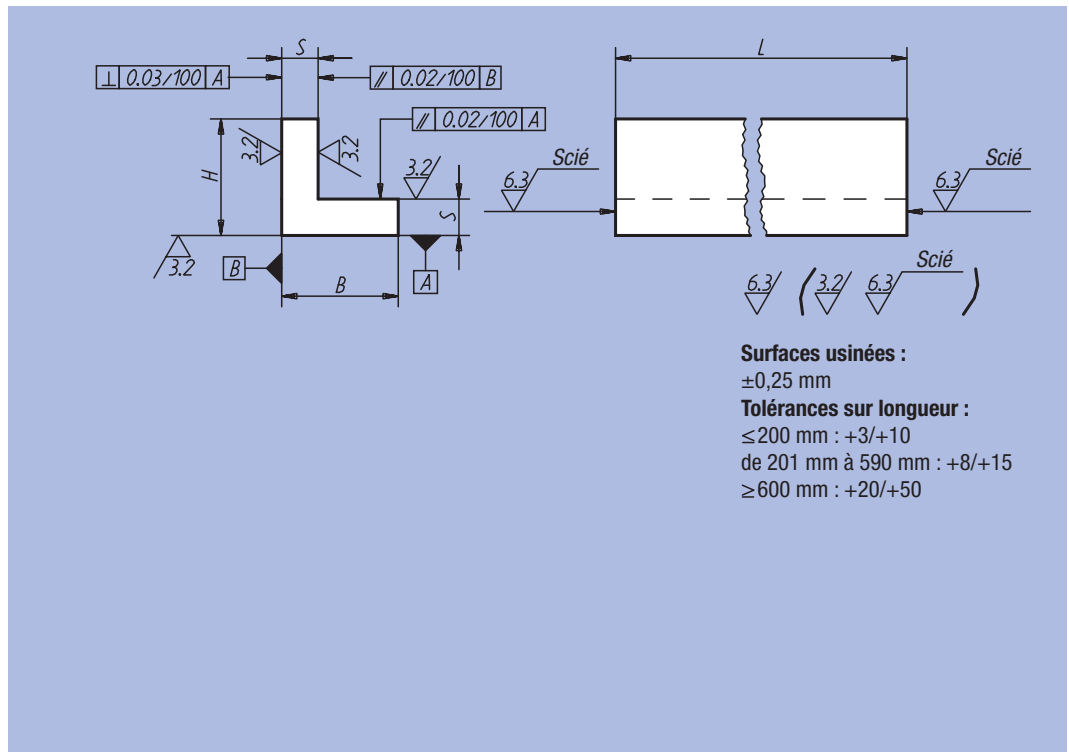
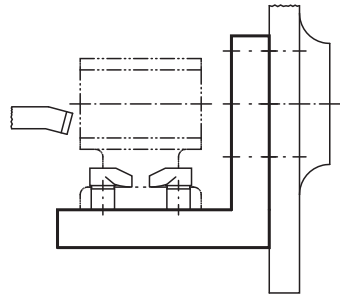

Référence	Finition	L = Longueur	B	H	S	kg, L/100
01380-01X	Fonte grise	150 / 300	32	32	10	0,40
01380-02X	Fonte grise	150 / 300	40	40	12	0,60
01380-03X	Fonte grise	150 / 300	50	50	12	0,80
01380-04X	Fonte grise	150 / 300	63	63	12	1,00
01380-05X	Fonte grise	200 / 300 / 600 / 800	80	80	16	1,65
01380-06X	Fonte grise	200 / 300 / 600 / 1000	100	100	20	2,60
01380-07X	Fonte grise	200 / 300 / 600 / 1000	125	125	20	3,30
01380-08X	Fonte grise	200 / 300 / 600	160	160	25	5,30
01380-09X	Fonte grise	200 / 300 / 600	200	200	32	8,45
01380-10X	Fonte grise	300 / 600	250	250	36	10,80
01380-11X	Fonte grise	300 / 600	315	315	36	15,50
01380-201X	Aluminium	150 / 300	32	32	10	0,14
01380-202X	Aluminium	150 / 300	40	40	12	0,20
01380-203X	Aluminium	150 / 300	50	50	12	0,30
01380-204X	Aluminium	150 / 300	63	63	12	0,35
01380-205X	Aluminium	200 / 300 / 600 / 800	80	80	16	0,55
01380-206X	Aluminium	200 / 300 / 600 / 1000	100	100	20	0,90
01380-207X	Aluminium	200 / 300 / 600 / 1000	125	125	20	1,15
01380-208X	Aluminium	200 / 300 / 600	160	160	25	1,80
01380-209X	Aluminium	200 / 300 / 600	200	200	32	2,90
01380-210X	Aluminium	300 / 600	250	250	36	3,70
01380-211X	Aluminium	300 / 600	315	315	36	5,30